



**AMETEK**  
**LAMB ELECTRIC**

**Product Bulletin**



Generation 2000 Vacuum Motors

Model: 119516-13

**SPECIAL FEATURES**

- Suitable for 24 volt DC operation
- UL Recognized, category PRGY2 (E47185)
- Provision for grounding
- Skeleton-frame design
- Epoxy painted fan case
- Patented air seal bearing construction; U.S. Patent #1,417,200
- The Lamb Electric vacuum motor line offers a wide range of performance levels to meet design needs.

**Model 119516-13 is the G2K replacement for model 116555-13.**

**DESCRIPTION**

- Two stage
- 24 volts
- 5.7"/145 mm diameter
- Double ball bearings
- Single speed
- Peripheral bypass discharge
- Thermoset fan end bracket
- Thermoset commutator bracket

**DESIGN APPLICATION**

- Equipment operating in environments requiring separation of working air from motor ventilating air
- Designed to handle clean, dry, filtered air only

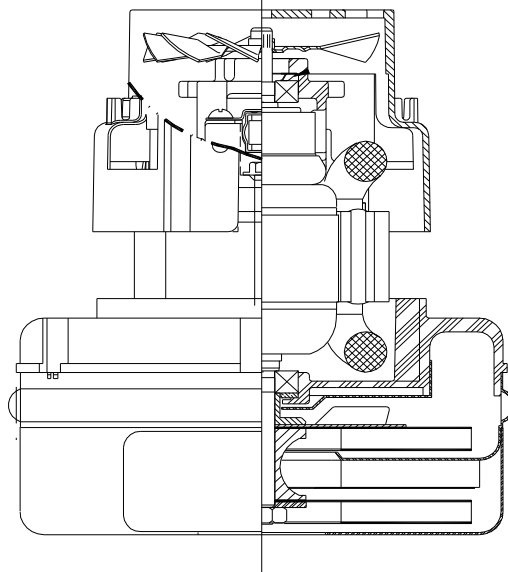

**TYPICAL MOTOR PERFORMANCE.\***

(At 24 volts DC, test data is corrected to standard conditions of 29.92 Hg, 68° F.)

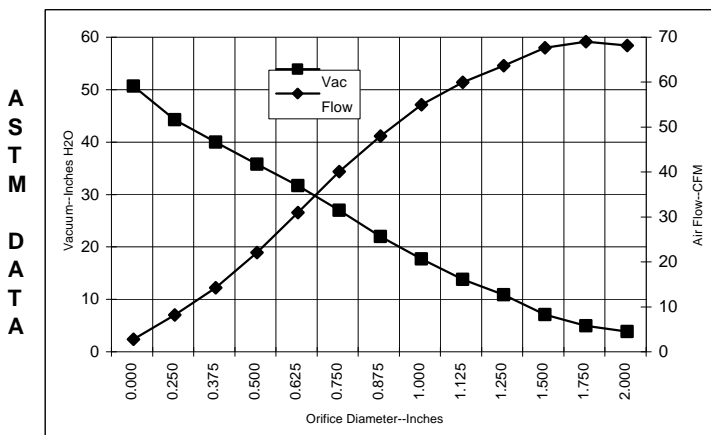

Orifice (Inches)	Amps	Watts (In)	RPM	Vac (In.H2O)	Flow (CFM)	Air Watts
2.000	16.9	416	12767	1.5	65.4	12
1.750	16.9	416	12700	2.6	66.2	20
1.500	16.9	418	12700	4.7	64.9	36
1.250	17.0	419	12683	8.5	60.9	61
1.125	17.0	419	12650	11.4	57.2	77
1.000	16.9	416	12750	15.3	52.2	93
0.875	16.7	412	12883	19.6	45.2	104
0.750	16.2	401	13067	24.6	37.3	108
0.625	15.6	387	13500	29.3	28.2	97
0.500	14.9	370	14083	33.4	19.3	76
0.375	14.2	350	14700	37.6	11.5	51
0.250	13.4	332	15500	41.9	5.4	27
0.000	12.8	315	16083	48.3	0.0	0

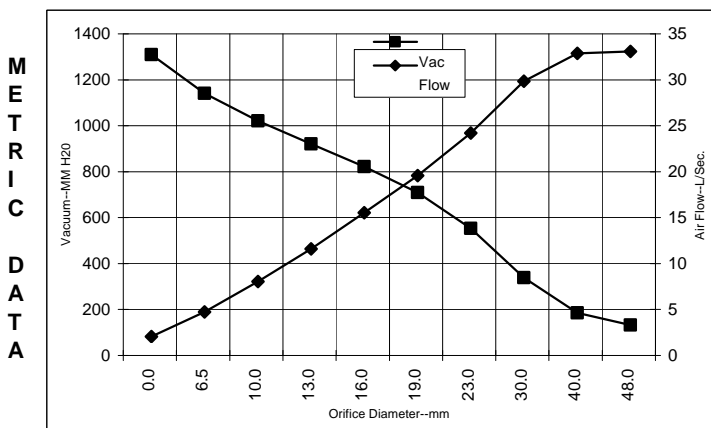

Orifice (mm)	Amps	Watts (In)	RPM	Vac (mm H2O)	Flow (L/Sec)	Air Watts
48.0	16.9	416	12738	50	31.0	15
40.0	16.9	417	12700	103	30.8	31
30.0	17.0	419	12665	256	27.8	70
23.0	16.7	413	12850	471	22.2	101
19.0	16.2	401	13076	627	17.5	108
16.0	15.6	388	13483	739	13.5	97
13.0	15.0	372	14025	838	9.5	78
10.0	14.3	353	14607	939	6.0	55
6.5	13.4	333	15460	1059	2.7	28
0.0	12.8	315	16083	1227	0.0	0

Note: Metric performance data is calculated from the ASTM data above.

\* Data represents performance of a typical motor sampled from a large production quantity. Individual motor data may vary due to normal manufacturing variations.

Test Specs:	24 volts	Minimum Sealed Vacuum:	45.1"	ORIFICE:	7/8 "	Minimum Vacuum:	17.5"	Maximum Watts:	480
-------------	----------	------------------------	-------	----------	-------	-----------------	-------	----------------	-----

DIMENSIONS



NOTES:

1. LEADS: 14 GA STRANDED, LEADS CAN BE ANY COLOR EXCEPT GREEN OR GREEN WITH YELLOW STRIPE.
2. RECOMMENDED SCREW SIZE 10-16 TYPE B1 OR TYPE 25 THREAD CUTTING SCREW, MAXIMUM PENETRATION [17.40]/.685.
3. MOTOR IDENTIFICATION: MANUFACTURER'S NAME, MODEL NUMBER, VOLTAGE, FREQUENCY, INSPECTOR'S CODE, DATE OF MANUFACTURE, AGENCY RECOGNITION CODE, PLANT LOCATION CODE, PATENT INFORMATION. ONE OR MORE OF THE FOLLOWING PATENTS APPLY TO THIS MOTOR: 5482378; 5736805; 4669952; 4684835. AND MADE IN THE USA.
4. ALLOW [0.0016 SQ M]/2.5 SQ IN. FOR COOLING AIR INTAKE.
5. COOLING AIR INTAKE MUST BE SEPERATED FROM COOLING AIR EXHAUST.
6. COOLING AIR EXHAUST MUST BE SEPERATED FROM VACUUM EXHAUST.
7. MOUNTING MUST NOT RESTRICT THIS DIAMETER.

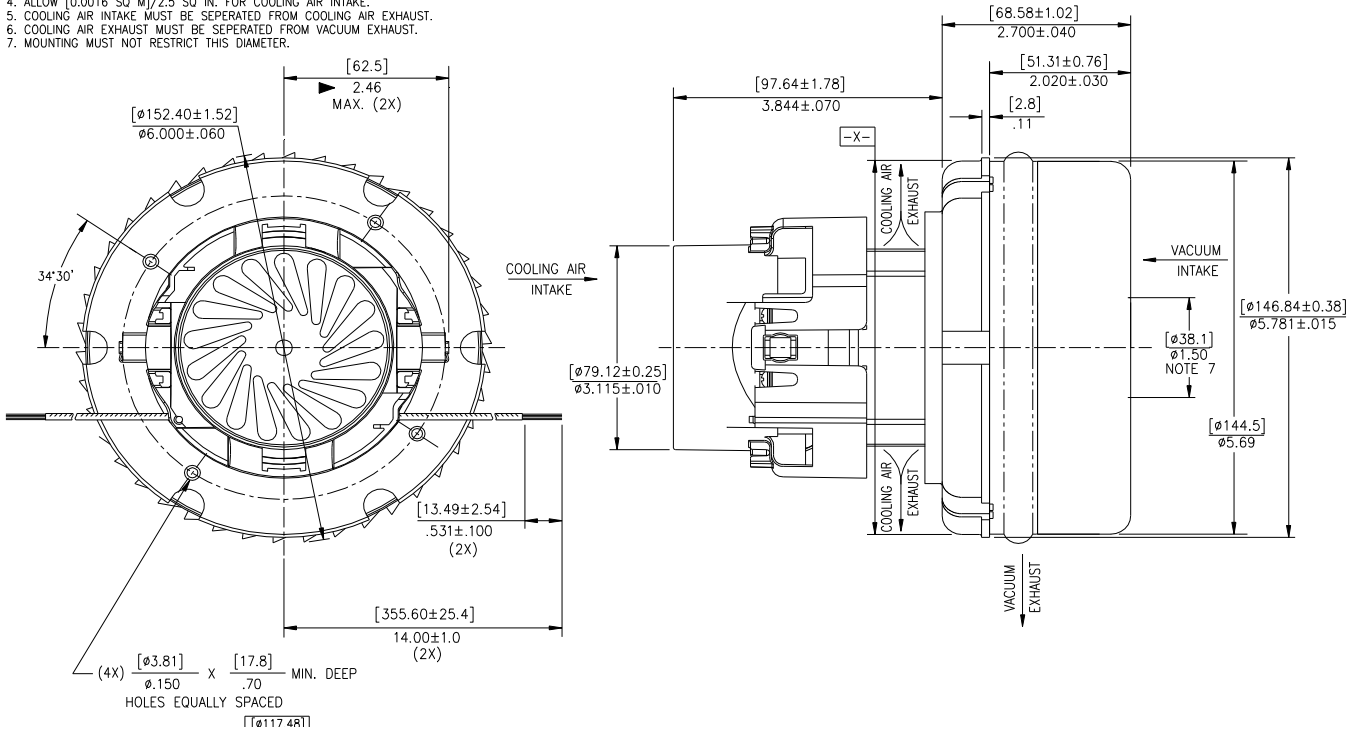

**IMPORTANT NOTE:** Pictorial and dimensional data are subject to change without notice. Contact factory for current revision levels.

**WARNING** - When using AMETEK Lamb Electric bypass motors in machines that come in contact with foam, liquid (including water), or other foreign substances, the machine must be designed and constructed to prevent those substances from reaching the fan system, motor housing, and electrical components. Lamb Electric vacuum motors other than hazardous duty models should not be applied in machines that come in contact with dry chemicals or other volatile materials. Failure to observe these precautions could cause flashing (depending on volatility) or electrical shock which could result in property damage and severe bodily injury, including death in extreme cases. All applications incorporating Lamb Electric motors should be submitted to appropriate organizations or agencies for testing specifically related to the safety of your equipment.

**AMETEK/Lamb Electric Division**  
 627 Lake Street  
 Kent, Ohio 44240  
 U.S.A.  
 Tel: (330) 673-3451  
 Fax: (330) 673-8994

**Ametek GmbH**  
 P. O. Box 1251  
 D-71667 Marbach  
 Germany  
 Phone: + 49-714-484-9512  
 Fax: + 49-714-484-9513

**AMETEK/Singapore Private Limited**  
 10 Ang Mo Kio Street 65  
 # 05-12 Techpoint  
 Singapore 2056  
 Tel: + 65-484-2388  
 Fax: + 65-481-6588