



DESCRIPTION

- Three stage
- 230 volts
- 7.2"/183 mm diameter
- Double ball bearings
- Single speed
- Tangential bypass discharge
- Aluminum fan end bracket
- Aluminum commutator bracket

DESIGN APPLICATION

- Equipment operating in environments requiring separation of working air from motor ventilating air.
- Designed to handle clean, dry, filtered air only.

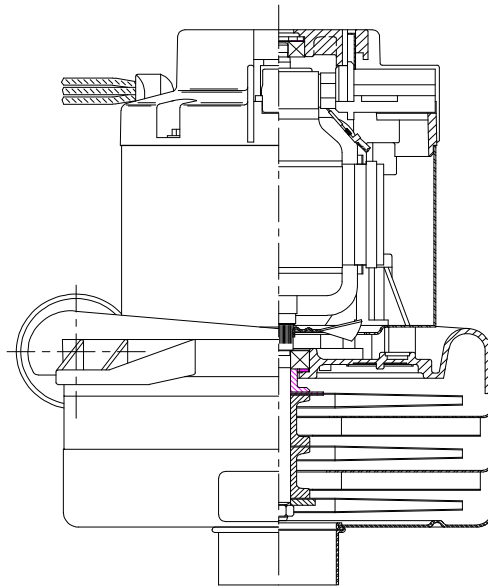

SPECIAL FEATURES

- Suitable for 230 volt AC operation, 50/60 Hz
- UL recognized, category PRGY2 (E47185)
- 10 mm shaft and bearing system
- Epoxy painted fan case
- Non-loading fans
- Provision for grounding
- Aluminum fan end bracket designed to dampen vibration and improve durability
- The Lamb Electric vacuum motor line offers a wide range of performance levels to meet design needs
- 17 Version with inlet tube

TYPICAL MOTOR PERFORMANCE.*

(At 230 volts, 60Hz, test data is corrected to standard conditions of 29.92 Hg, 68° F.)

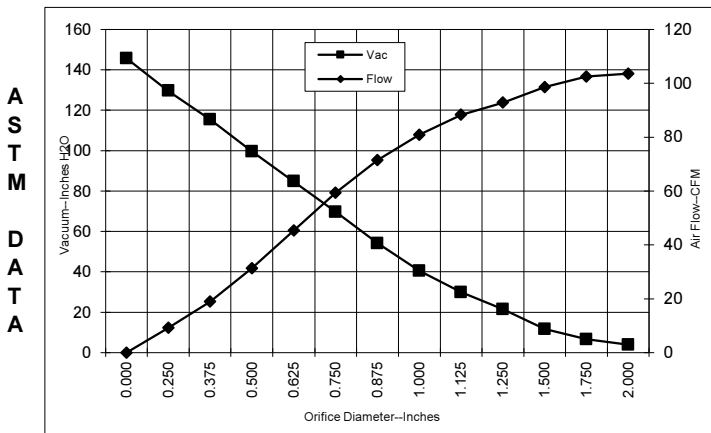

Orifice (Inches)	Amps	Watts (In)	RPM	Vac (In.H2O)	Flow (CFM)	Air Watts
2.000	7.7	1650	15190	3.9	103.5	48
1.750	7.7	1652	15190	6.6	102.5	80
1.500	7.8	1653	15160	11.7	98.6	136
1.250	7.8	1656	15140	21.5	92.8	235
1.125	7.8	1656	15140	29.9	88.3	310
1.000	7.8	1652	15170	40.5	80.9	385
0.875	7.7	1635	15210	54.1	71.5	455
0.750	7.5	1595	15450	69.6	59.3	486
0.625	7.1	1518	15930	84.8	45.3	452
0.500	6.5	1410	16670	99.6	31.4	367
0.375	5.9	1278	17630	115.4	18.9	257
0.250	5.3	1152	18730	129.6	9.2	140
0.000	4.8	1048	19730	145.7	0.0	0

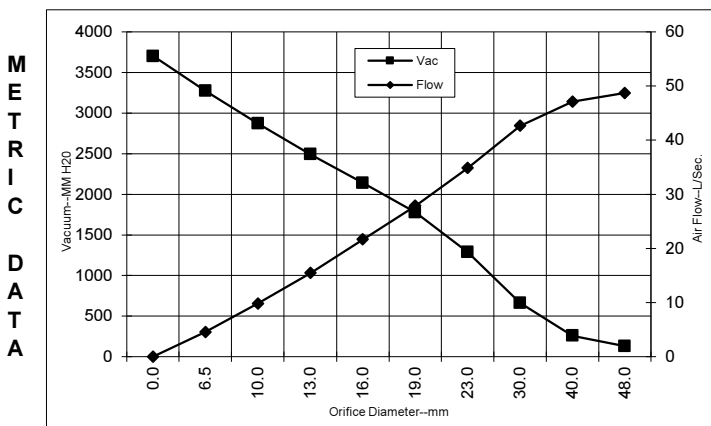

Orifice (mm)	Amps	Watts (In)	RPM	Vac (mm H2O)	Flow (L/Sec)	Air Watts
48.0	7.7	1651	15190	130	48.7	62
40.0	7.7	1653	15169	259	47.1	119
30.0	7.8	1656	15140	663	42.6	276
23.0	7.7	1639	15200	1288	34.9	438
19.0	7.5	1593	15460	1776	27.9	485
16.0	7.1	1521	15911	2139	21.7	454
13.0	6.6	1421	16596	2492	15.5	376
10.0	6.0	1298	17486	2871	9.8	274
6.5	5.3	1158	18675	3274	4.6	146
0.0	4.8	1048	19730	3701	0.0	0

Note: Metric performance data is calculated from the ASTM data above.

* Data represents performance of a typical motor sampled from a large production quantity. Individual motor data may vary due to normal manufacturing variations.

Test Specs:	230 volts	Minimum Sealed Vacuum:	133.0	ORIFICE:	7/8 "	Minimum Watts:	50.0	Maximum Watts:	1745
--------------------	------------------	-------------------------------	--------------	-----------------	--------------	-----------------------	-------------	-----------------------	-------------

DIMENSIONS

NOTES:

- LEADS: 16GA. STRANDED, ONE BLACK AND ONE WHITE. GROUND LEAD: 18GA. STRANDED, GREEN WITH YELLOW STRIPE.
- MOTOR IDENTIFICATION: MANUFACTURER'S NAME, MODEL NUMBER, VOLTAGE, FREQUENCY, INSPECTOR'S CODE WITH "FF" SUFFIX, DATE OF MANUFACTURE, AGENCY RECOGNITION CODE, PLANT LOCATION CODE, PATENTS: "4698534; 4621991", AND MADE IN THE USA.

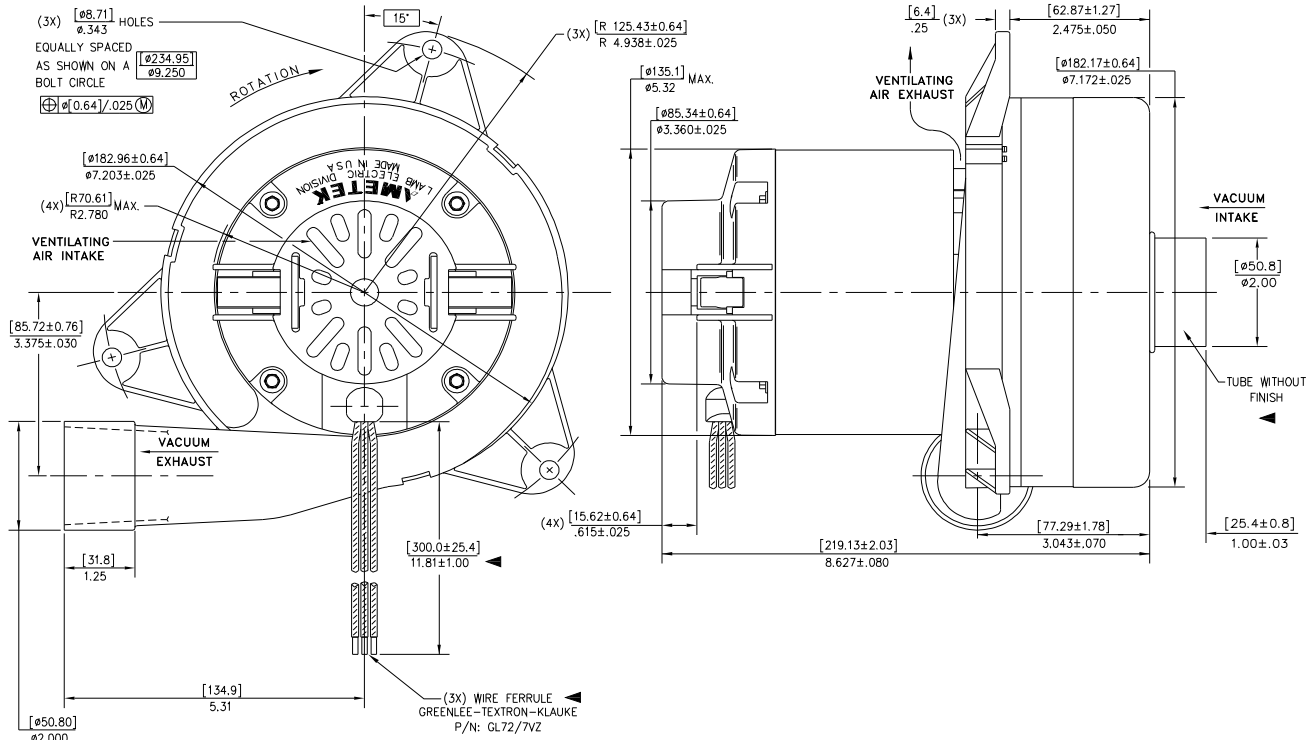

IMPORTANT NOTE: Pictorial and dimensional data are subject to change without notice. Contact factory for current revision levels.

WARNING - When using AMETEK Lamb Electric bypass motors in machines that come in contact with foam, liquid (including water), or other foreign substances, the machine must be designed and constructed to prevent those substances from reaching the fan system, motor housing, and electrical components. Lamb Electric vacuum motors other than hazardous duty models should not be applied in machines that come in contact with dry chemicals or other volatile materials. Failure to observe these precautions could cause flashing (depending on volatility) or electrical shock which could result in property damage and severe bodily injury, including death in extreme cases. All applications incorporating Lamb Electric motors should be submitted to appropriate organizations or agencies for testing specifically related to the safety of your equipment.

AMETEK Dynamic Fluid Solutions
www.ametekdfs.com