



AMETEK

LAMB ELECTRIC

Product Bulletin

Model: 116598-13

DESCRIPTION

- Three stage
- 24 volts
- 5.7"/145 mm diameter
- Double ball bearings
- Single speed
- ACUSTEK® low-noise peripheral bypass discharge
- Thermoset fan end bracket
- Aluminum commutator bracket

DESIGN APPLICATION

- Equipment operating in environments requiring separation of working air from motor ventilating air
- Designed to handle clean, dry, filtered air only

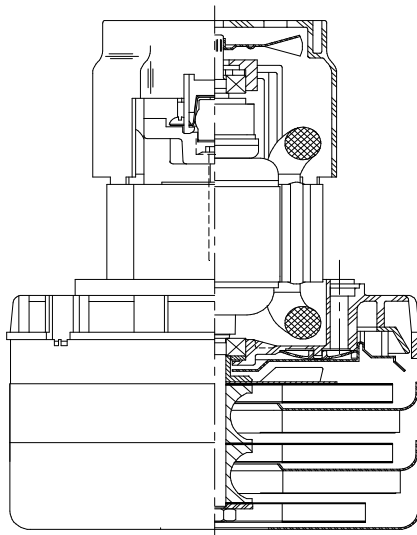

SPECIAL FEATURES

- Suitable for 24 volt DC operation
- UL Recognized, category PRGY2 (E47185)
- Provision for grounding
- Skeleton-frame design
- Epoxy painted fan case
- Patented air seal bearing construction. U.S. Patent #4,088,424
- ACUSTEK® low-noise design, U.S. Patent #1,417,200
- The Lamb Electric vacuum motor line offers a wide range of performance levels to meet design needs.

TYPICAL MOTOR PERFORMANCE.*

(At 24 volts DC, test data is corrected to standard conditions of 29.92 Hg, 68° F.)

ASTM DATA

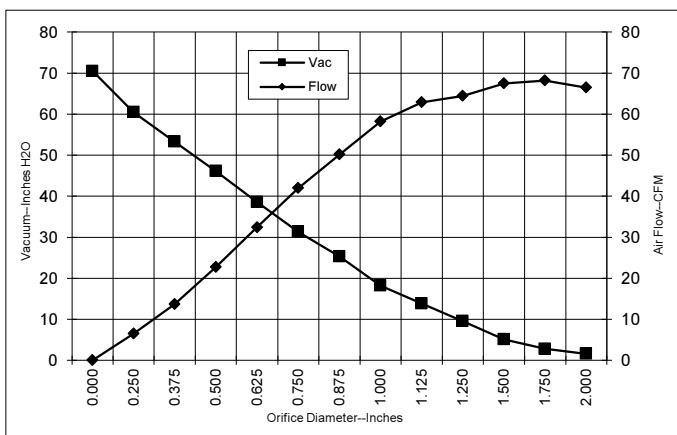

Orifice (Inches)	Amps	Watts (In)	RPM	Vac (In.H ₂ O)	Flow (CFM)	Air Watts
2.000	22.5	549	13678	1.6	66.5	12
1.750	22.5	551	13630	2.8	68.2	22
1.500	22.7	554	13566	5.1	67.5	40
1.250	23.0	562	13465	9.5	64.5	72
1.125	23.1	565	13429	13.8	62.9	102
1.000	23.2	566	13411	18.2	58.2	125
0.875	23.2	564	13426	25.3	50.2	149
0.750	22.7	554	13541	31.3	42.0	154
0.625	21.8	532	13951	38.6	32.4	147
0.500	20.6	501	14598	46.1	22.7	123
0.375	19.0	462	15410	53.3	13.7	86
0.250	17.5	426	16280	60.5	6.5	46
0.000	16.5	402	17277	70.5	0.0	0

METRIC DATA

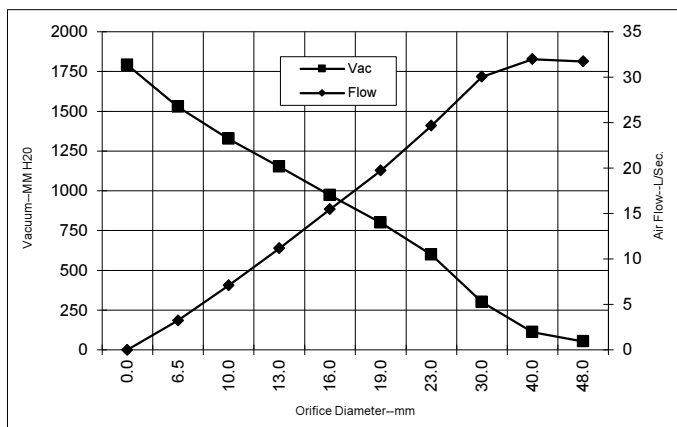

Orifice (mm)	Amps	Watts (In)	RPM	Vac (mm H ₂ O)	Flow (L/Sec)	Air Watts
48.0	22.5	550	13657	53	31.7	16
40.0	22.7	553	13585	111	32.0	35
30.0	23.1	564	13445	301	30.0	89
23.0	23.2	565	13422	598	24.6	143
19.0	22.7	554	13549	799	19.7	154
16.0	21.8	533	13935	973	15.5	147
13.0	20.7	504	14533	1152	11.2	125
10.0	19.2	468	15288	1326	7.1	92
6.5	17.6	428	16237	1528	3.2	48
0.0	16.5	402	17277	1791	0.0	0

Note: Metric performance data is calculated from the ASTM data above.

* Data represents performance of a typical motor sampled from a large production quantity. Individual motor data may vary due to normal manufacturing variations.

Test Specs:	24 volts	Minimum Sealed Vacuum:	62.0"	ORIFICE:	7/8 "	Minimum Vacuum:	22.0"	Maximum Watts:	640
--------------------	-----------------	-------------------------------	--------------	-----------------	--------------	------------------------	--------------	-----------------------	------------

DIMENSIONS

NOTES:

1. LEADS: 14GA STRANDED, LEADS CAN BE ANY COLOR EXCEPT GREEN OR GREEN WITH YELLOW STRIPE.
2. GROUNDING OR EARTHING PROVISIONS: USE HOLES AS INDICATED FOR GROUNDING OR EARTHING. REFER TO APPROPRIATE LISTING OR REGULATORY AGENCY FOR PROPER METHOD OF GROUNDING OR EARTHING.

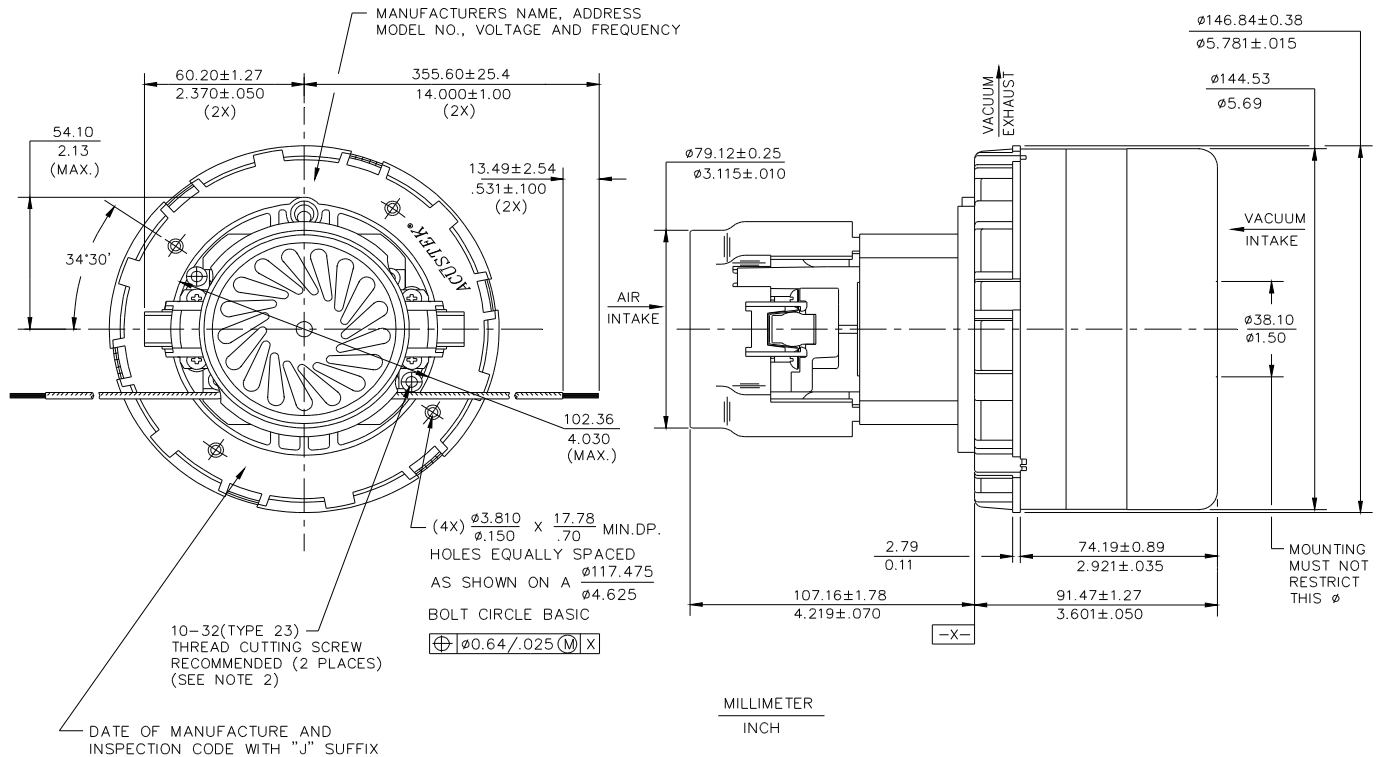

IMPORTANT NOTE: Pictorial and dimensional data are subject to change without notice. Contact factory for current revision levels.

WARNING - When using AMETEK Lamb Electric bypass motors in machines that come in contact with foam, liquid (including water), or other foreign substances, the machine must be designed and constructed to prevent those substances from reaching the fan system, motor housing, and electrical components. Lamb Electric vacuum motors other than hazardous duty models should not be applied in machines that come in contact with dry chemicals or other volatile materials. Failure to observe these precautions could cause flashing (depending on volatility) or electrical shock which could result in property damage and severe bodily injury, including death in extreme cases. All applications incorporating Lamb Electric motors should be submitted to appropriate organizations or agencies for testing specifically related to the safety of your equipment.

AMETEK Dynamic Fluid Solutions
www.ametekdfs.com