



Model: 119413-00
119413-13*

SPECIAL FEATURES

- Suitable for 120 volt AC operation, 50/60 Hz
- UL recognized, category PRGY2 (E471885)
- Provision for grounding
- Skeleton-frame design
- ACUSTEK® low-noise peripheral bypass discharge
- ACUSTEK® low-noise design, U.S. Patent #1,417,2000
- The Lamb Electric vacuum motor line offers a wide range of performance levels to meet design needs

Models 119413-00 and 119413-13 are G2K replacements for models 116757-00 and 116757-13

***Model 119413-13 features patented air seal bearing construction, U.S. Patent #4,088,424 and epoxy painted fan case**

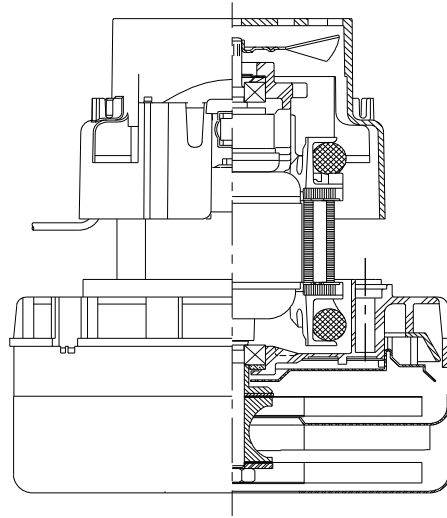

DESCRIPTION

- Two stage
- 120 volts
- 5.7"/145 mm diameter
- Double ball bearings
- Single speed
- ACUSTEK® low-noise peripheral bypass discharge
- Thermoset fan end bracket
- Thermoset commutator bracket

DESIGN APPLICATION

- Equipment operating in environments requiring separation of working air from motor ventilating air
- Designed to handle clean, dry, filtered air only

TYPICAL MOTOR PERFORMANCE.*

(At 120 volts, 60Hz, test data is corrected to standard conditions of 29.92 Hg, 68° F.)

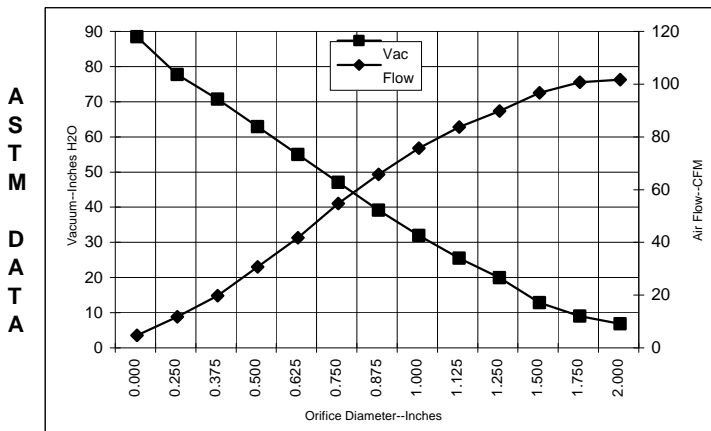

Orifice (Inches)	Amps	Watts (In)	RPM	Vac (In.H ₂ O)	Flow (CFM)	Air Watts
2.000	7.8	901	17649	3.3	97.0	37
1.750	7.8	905	17573	5.5	96.0	62
1.500	7.9	911	17484	9.3	92.0	100
1.250	7.9	918	17431	16.4	85.0	163
1.125	7.9	917	17389	21.9	79.0	204
1.000	7.9	912	17487	28.4	71.0	237
0.875	7.7	895	17692	35.6	61.0	255
0.750	7.4	862	18054	43.5	50.0	253
0.625	7.0	817	18693	51.4	37.0	225
0.500	6.5	758	19523	59.3	26.0	179
0.375	5.9	694	20516	67.2	15.0	122
0.250	5.4	643	21496	74.2	7.0	63
0.000	5.0	596	22332	84.9	0.0	0

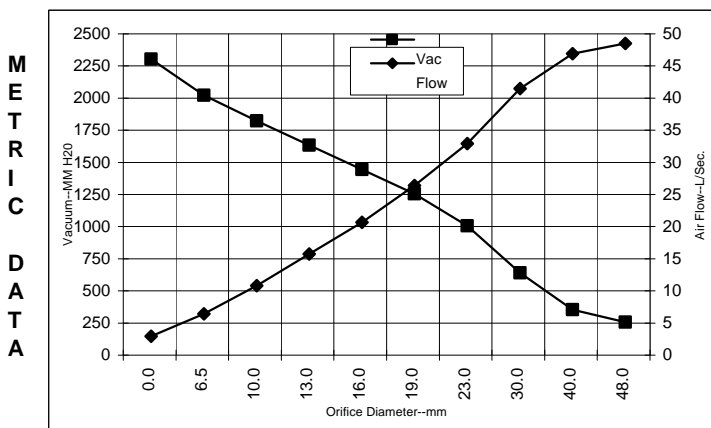

Orifice (mm)	Amps	Watts (In)	RPM	Vac (mm H ₂ O)	Flow (L/Sec)	Air Watts
48.0	7.8	903	17616	108	45.6	48
40.0	7.9	909	17511	207	44.0	89
30.0	7.9	917	17408	493	38.6	186
23.0	7.8	899	17641	859	30.0	251
19.0	7.4	861	18067	1109	23.5	252
16.0	7.0	819	18667	1298	17.7	226
13.0	6.6	764	19440	1486	12.8	184
10.0	6.0	704	20367	1677	7.9	131
6.5	5.4	646	21447	1876	3.5	66
0.0	5.0	596	22332	2156	0.0	0

Note: Metric performance data is calculated from the ASTM data above.

* Data represents performance of a typical motor sampled from a large production quantity. Individual motor data may vary due to normal manufacturing variations.

Test Specs:	120 volts	Minimum Sealed Vacuum:	80.0"	ORIFICE:	7/8 "	Minimum Vacuum:	33.0"	Maximum Watts:	1050
--------------------	-----------	-------------------------------	-------	-----------------	-------	------------------------	-------	-----------------------	------

DIMENSIONS



NOTES:

1. RECOMMENDED SCREW SIZE 10-16 TYPE BT OR TYPE 25 THREAD CUTTING SCREW. MAXIMUM PENETRATION [17.40]/.685.
2. MOTOR IDENTIFICATION: MANUFACTURER'S NAME, MODEL NUMBER, VOLTAGE, FREQUENCY, INSPECTORS CODE, DATE OF MANUFACTURE, AGENCY RECOGNITION CODE, PLANT LOCATION CODE, PATENT INFORMATION * ONE OR MORE OF THE FOLLOWING PATENTS APPLY TO THIS MOTOR: 5482378; 5736805; 4669952; 4684835.* AND MADE IN THE USA.
3. ALLOW [0.0016 SQ M]/2.5 SQ IN. FOR COOLING AIR INTAKE.
4. COOLING AIR INTAKE MUST BE SEPERATED FROM COOLING AIR EXHAUST.
5. COOLING AIR EXHAUST MUST BE SEPERATED FROM VACUUM AIR EXHAUST.
6. GROUND LEAD: 18 GAUGE STRANDED; COLOR: GREEN WITH YELLOW STRIPE.

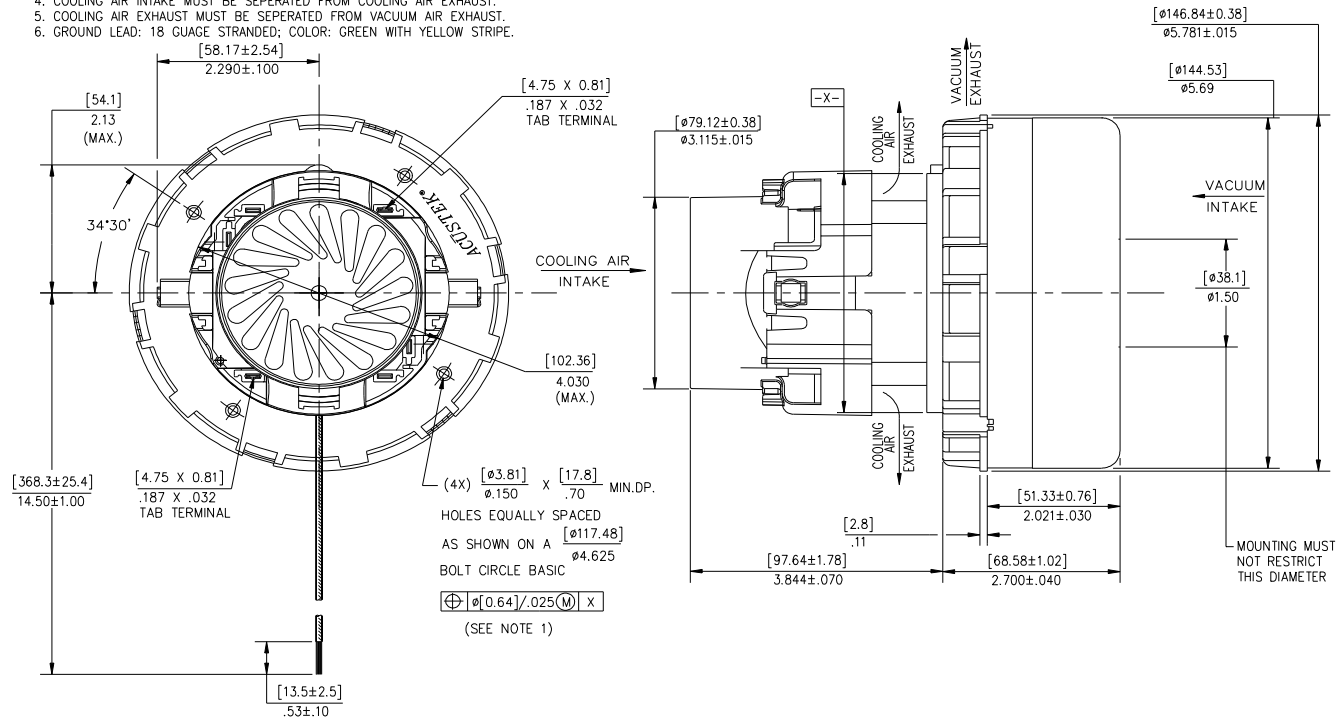

IMPORTANT NOTE: Pictorial and dimensional data are subject to change without notice. Contact factory for current revision levels.

WARNING - When using AMETEK Lamb Electric bypass motors in machines that come in contact with foam, liquid (including water), or other foreign substances, the machine must be designed and constructed to prevent those substances from reaching the fan system, motor housing, and electrical components. Lamb Electric vacuum motors other than hazardous duty models should not be applied in machines that come in contact with dry chemicals or other volatile materials. Failure to observe these precautions could cause flashing (depending on volatility) or electrical shock which could result in property damage and severe bodily injury, including death in extreme cases. All applications incorporating Lamb Electric motors should be submitted to appropriate organizations or agencies for testing specifically related to the safety of your equipment.

AMETEK/Lamb Electric Division
 627 Lake Street
 Kent, Ohio 44240
 U.S.A.
 Tel: (330) 673-3451
 Fax: (330) 673-8994

Ametek GmbH
 P. O. Box 1251
 D-71667 Marbach
 Germany
 Phone: + 49-714-484-9512
 Fax: + 49-714-484-9513

AMETEK/Singapore Private Limited
 10 Ang Mo Kio Street 65
 # 05-12 Techpoint
 Singapore 2056
 Tel: + 65-484-2388
 Fax: + 65-481-6588