

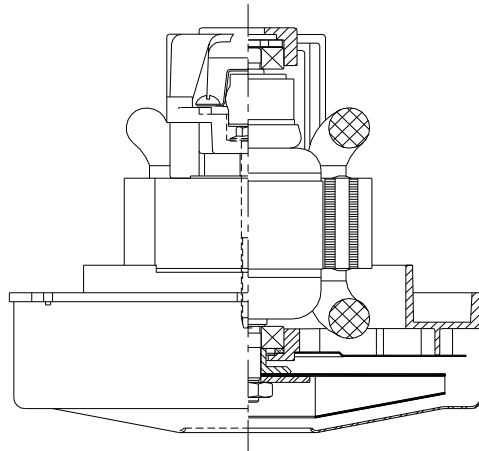

SPECIAL FEATURES

- Suitable for 120 volt AC operation, 50/60 Hz
- UL recognized, category PRGY2 (E47185)
- Provision for grounding
- Skeleton frame design
- Tapered fan system

The Lamb vacuum motor line offers a wide range of performance levels to meet design needs



DESCRIPTION

- Single stage
- 120 volts
- 5.7" (145mm) mm diameter
- Double ball bearings
- Single speed
- Thru-flow discharge
- Aluminum Hi-Eff fan end bracket
- Aluminum commutator bracket

DESIGN APPLICATION

- Equipment operating in environments requiring separation of working air from motor ventilating air.
- Designed to handle clean, dry, filtered air only.



TYPICAL MOTOR PERFORMANCE.*

(At 120 volts, 60Hz, test data is corrected to standard conditions of 29.92 Hg, 68° F.)

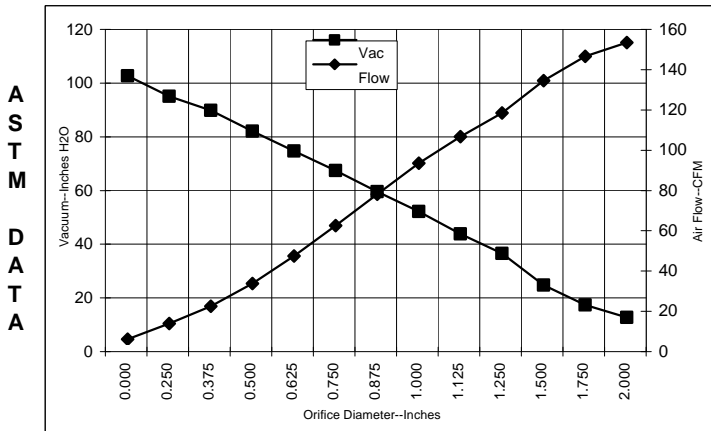

Orifice (Inches)	Amps	Watts (In)	RPM	Vac (In.H2O)	Flow (CFM)	Air Watts
2.000	11.0	1293	27000	8.1	147.3	141
1.750	11.3	1314	26790	12.7	140.4	210
1.500	11.5	1338	26490	20.1	128.4	304
1.250	11.6	1348	26500	31.9	112.4	422
1.125	11.4	1328	26630	39.2	100.6	464
1.000	11.1	1296	27090	47.6	87.4	489
0.875	10.6	1244	27690	54.9	72.0	464
0.750	10.0	1178	28530	62.8	56.4	416
0.625	9.4	1102	29650	70.1	41.3	340
0.500	8.6	1014	31130	77.4	27.7	252
0.375	7.8	926	32630	85.2	16.4	164
0.250	7.3	860	34270	90.5	7.8	83
0.000	6.9	818	35510	98.1	0.0	0

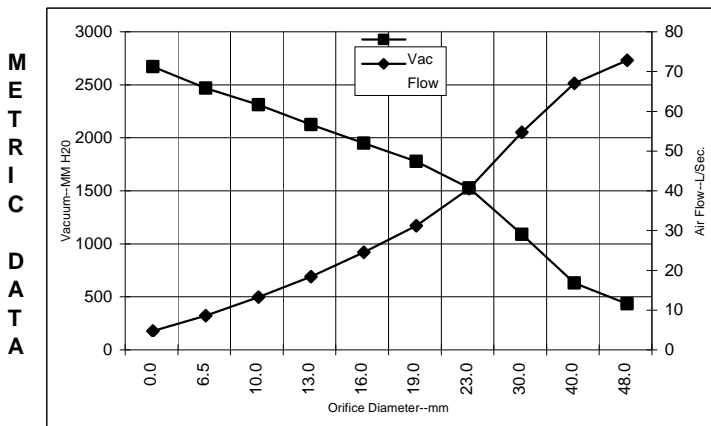

Orifice (mm)	Amps	Watts (In)	RPM	Vac (mm H2O)	Flow (L/Sec)	Air Watts
48.0	11.1	1302	26908	257	68.1	171
40.0	11.4	1331	26580	454	62.3	276
30.0	11.5	1337	26572	912	50.0	445
23.0	10.8	1257	27540	1348	35.8	470
19.0	10.0	1176	28552	1599	26.5	414
16.0	9.4	1105	29605	1773	19.8	343
13.0	8.7	1023	30982	1947	13.7	261
10.0	8.0	939	32405	2134	8.5	177
6.5	7.3	863	34188	2292	3.9	87
0.0	6.9	818	35510	2492	0.0	0

Note: Metric performance data is calculated from the ASTM data above.

* Data represents performance of a typical motor sampled from a large production quantity. Individual motor data may vary due to normal manufacturing variations.

Test Specs:	120 volt	Minimum Sealed Vacuum: 86	86.0"	ORIFICE: 7/8"	Minimum Vacuum: 4	47.0"	Maximum Watts:	1158
-------------	----------	---------------------------	-------	---------------	-------------------	-------	----------------	------

DIMENSIONS

NOTES: UNLESS OTHERWISE SPECIFIED.

1. LEADS: 18GA. STRANDED. LEADS CAN BE ANY COLOR EXCEPT GREEN OR GREEN WITH YELLOW STRIPE.
2. GROUNDING OR EARTHING PROVISIONS: USE HOLES AS INDICATED FOR GROUNDING OR EARTHING. REFER TO APPROPRIATE LISTING OR REGULATORY AGENCY FOR PROPER METHOD OF GROUNDING OR EARTHING.
3. MOTOR IDENTIFICATION: MANUFACTURER'S NAME, MODEL NUMBER, VOLTAGE, FREQUENCY, INSPECTOR'S CODE, DATE OF MANUFACTURE, AGENCY RECOGNITION CODE, PLANT LOCATION CODE AND COUNTRY OF ORIGIN.
4. MOUNTING MUST NOT RESTRICT THIS DIAMETER.

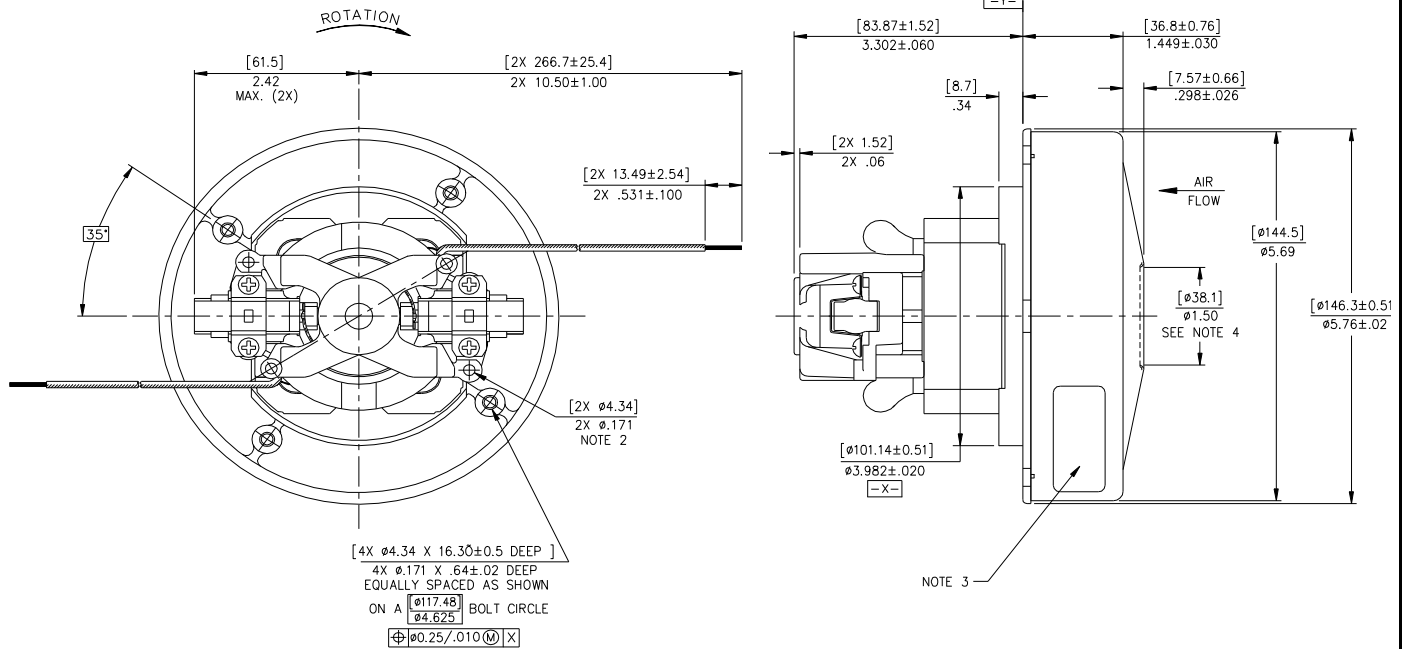

IMPORTANT NOTE: Pictorial and dimensional data are subject to change without notice. Contact factory for current revision levels.

WARNING - When using AMETEK Lamb Electric bypass motors in machines that come in contact with foam, liquid (including water), or other foreign substances, the machine must be designed and constructed to prevent those substances from reaching the fan system, motor housing, and electrical components. Lamb Electric vacuum motors other than hazardous duty models should not be applied in machines that come in contact with dry chemicals or other volatile materials. Failure to observe these precautions could cause flashing (depending on volatility) or electrical shock which could result in property damage and severe bodily injury, including death in extreme cases. All applications incorporating Lamb Electric motors should be submitted to appropriate organizations or agencies for testing specifically related to the safety of your equipment.

AMETEK/Lamb Electric Division
 627 Lake Street
 Kent, Ohio 44240
 U.S.A.
 Tel: (330) 673-3451 Fax: (330) 673-8994
 www.lambelectric.com