

LAMB ELECTRIC

Model: 117939-00

DESCRIPTION

- Three stages
- 120 volts
- 5.7"/145 mm diameter
- Double ball bearings
- Single speed
- ACUSTEK® low-noise peripheral bypass discharge
- Aluminum fan end bracket
- Aluminum commutator bracket

DESIGN APPLICATION

- Equipment operating in environments requiring separation of working air from motor ventilating air
- Designed to handle clean, dry, filtered air only

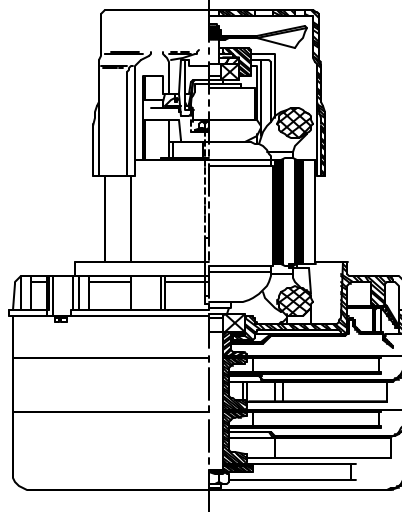

SPECIAL FEATURES

- Suitable for 120 volt AC operation, 50/60 Hz
- UL recognized, category PRGY2 (E47185)
- Provision for grounding
- Skeleton-frame design
- 10 mm shaft and bearing system
- Aluminum fan end bracket designed to dampen vibration and improve durability
- ACUSTEK® low-noise design, U.S. Patent #1,417,200
- The Lamb Electric vacuum motor line offers a wide range of performance levels to meet design needs

TYPICAL MOTOR PERFORMANCE.*

(At 120 volts, 60Hz, test data is corrected to standard conditions of 29.92 Hg, 68° F.)

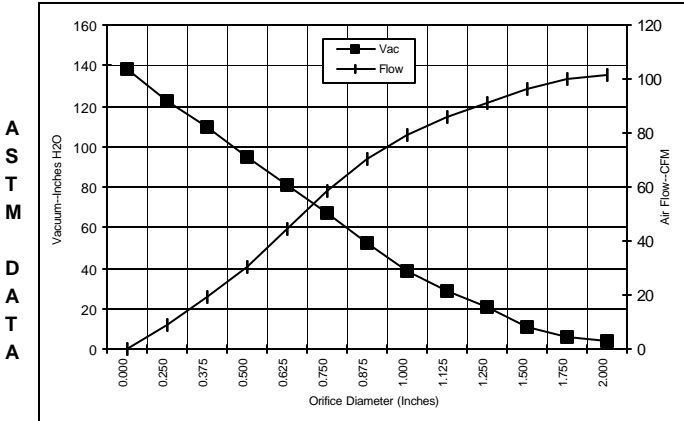

Orifice (Inches)	Amps	Watts (In)	RPM	Vac (In.H ₂ O)	Flow (CFM)	Air Watts
2.000	13.6	1554	20392	3.8	101.2	45
1.750	13.6	1559	20408	6.3	100.0	74
1.500	13.7	1563	20358	11.1	96.3	126
1.250	13.9	1586	20264	20.5	90.9	220
1.125	14.0	1594	20196	28.3	86.1	286
1.000	14.1	1605	20144	38.8	79.3	361
0.875	14.0	1601	20154	51.9	70.1	428
0.750	13.6	1557	20426	66.9	58.2	458
0.625	12.7	1456	21004	81.4	44.4	425
0.500	11.6	1331	21860	95.3	30.6	342
0.375	10.3	1192	23066	109.5	19.5	238
0.250	9.2	1069	24320	122.0	8.9	128
0.000	8.3	969	25474	138.6	0.0	0

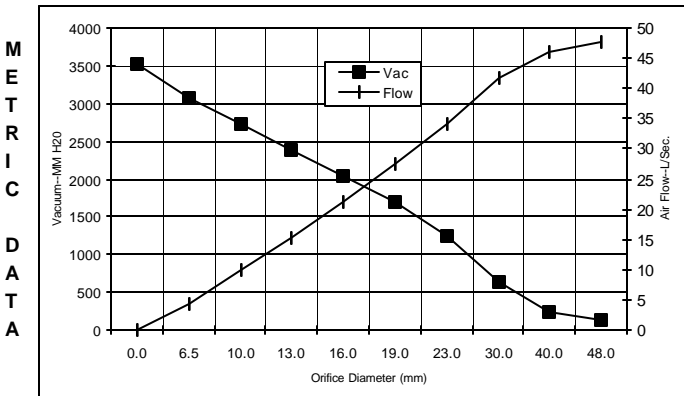

Orifice (mm)	Amps	Watts (In)	RPM	Vac (mm H ₂ O)	Flow (L/Sec)	Air Watts
48.0	13.6	1556	20399	124	47.5	58
40.0	13.7	1562	20373	245	46.0	110
30.0	14.0	1590	20227	630	41.7	256
23.0	14.0	1602	20152	1235	34.2	411
19.0	13.6	1555	20438	1707	27.3	457
16.0	12.7	1460	20981	2053	21.2	426
13.0	11.7	1344	21774	2385	15.1	350
10.0	10.5	1213	22885	2727	10.0	254
6.5	9.3	1075	24257	3083	4.5	134
0.0	8.3	969	25474	3520	0.0	0

Note: Metric performance data is calculated from the ASTM data above.

* Data represents performance of a typical motor sampled from a large production quantity. Individual motor data may vary due to normal manufacturing variat

Test Specs:	120 volts	Minimum Sealed Vacuum:	130.0"	ORIFICE:	7/8"	Minimum Vacuum:	400"	Maximum Watts:	1700
-------------	-----------	------------------------	--------	----------	------	-----------------	------	----------------	------

DIMENSIONS

NOTES:

1. LEADS 18GA STRANDED LEADS CAN BE ANY COLOR EXCEPT GREEN OR GREEN WITH YELLOW STRIPE
2. GROUNDED OR EARTHING PROVISIONS SEE HOLES AS INDICATED FOR COOLING OR EARTHING
3. REFER TO APPROPRIATE LISTING OR REGULATORY AGENCY FOR PROPER METHOD OF GROUNDED OR EARTHING
4. RECOMMENDED SCREW SIZE 10-18 TYPE B1 OR 28 THREAD CUTTING SCREW. VACUUM PENETRATION (7.62)/AREA
5. ALLOW (18x28 MM SQUARE)/.5 IN SQUARE FOR COOLING AIR INTAKE
6. COOLING AIR INTAKE MUST BE SEPARATED FROM COOLING AIR EXHAUST
7. VACUUM EXHAUST MUST BE SEPARATED FROM COOLING AIR EXHAUST
8. MOTOR IDENTIFICATION MODEL NUMBER, DATE OF MANUFACTURE, UL & CSA RECOGNITION CODE, INSPECTOR'S CODE, MANUFACTURER'S NAME, MADE IN U.S.A., VOLTAGE AND FREQUENCY

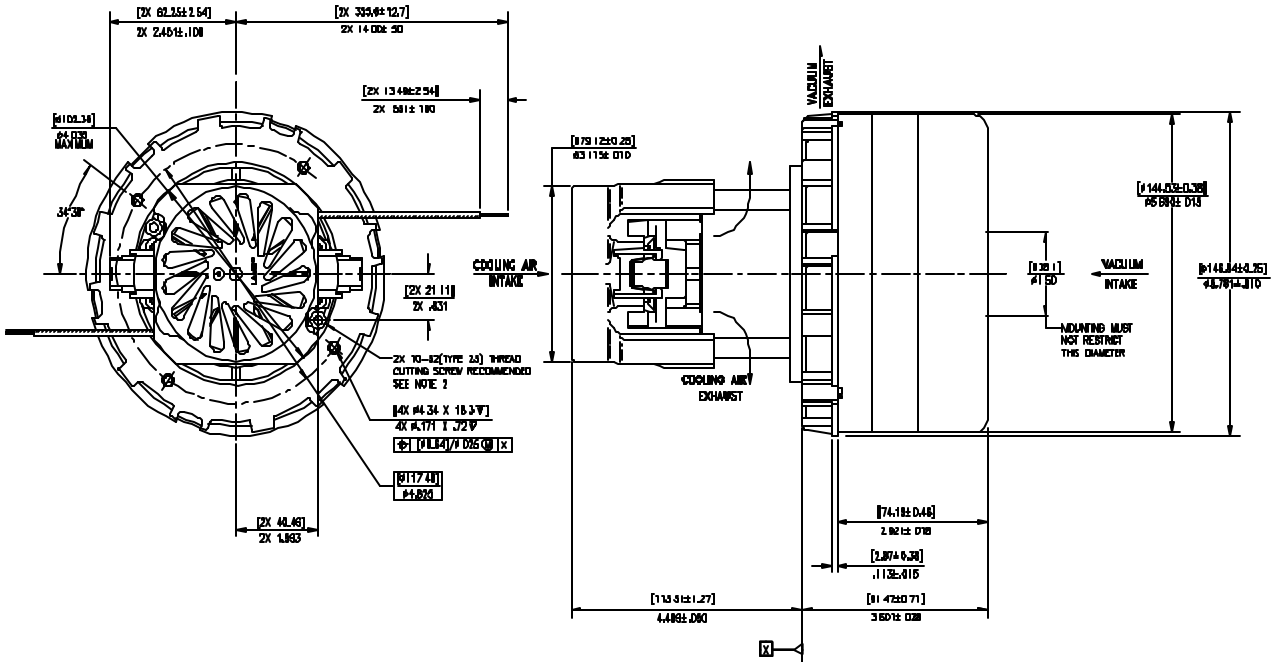

IMPORTANT NOTE: Pictorial and dimensional data are subject to change without notice. Contact factory for current revision levels.

WARNING - When using AMETEK Lamb Electric bypass motors in machines that come in contact with foam, liquid (including water), or other foreign substances, the machine must be designed and constructed to prevent those substances from reaching the fan system, motor housing, and electrical components. Lamb Electric vacuum motors other than hazardous duty models should not be applied in machines that come in contact with dry chemicals or other volatile materials. Failure to observe these precautions could cause flashing (depending on volatility) or electrical shock which could result in property damage and severe bodily injury, including death in extreme cases. All applications incorporating Lamb Electric motors should be submitted to appropriate organizations or agencies for testing specifically related to the safety of your equipment.

AMETEK/Lamb Electric Division
 627 Lake Street
 Kent, Ohio 44240
 U.S.A.
 Tel: (330) 673-3451
 Fax: (330) 673-8994

Ametek GmbH
 Weillimdorfer Str. 47
 D-70825 Korntal-Munchingen
 Germany
 Phone: + 49-711-838-7876
 Fax: + 49-711-838-7862

AMETEK/Singapore Private Limited
 10 Ang Mo Kio Street 65
 # 05-12 Techpoint
 Singapore 2056
 Tel: + 65-484-2388
 Fax: + 65-481-6588