

LAMB ELECTRIC

Model: 117743-00
117743-13*

DESCRIPTION

- Three stage
- 240 volts
- 7.2"/183 mm diameter
- Double ball bearings
- Single speed
- Tangential bypass discharge
- Thermoset fan end bracket
- Thermoset commutator bracket

DESIGN APPLICATION

- Equipment operating in environments requiring separation of working air from motor ventilating air
- Designed to handle clean, dry, filtered air only

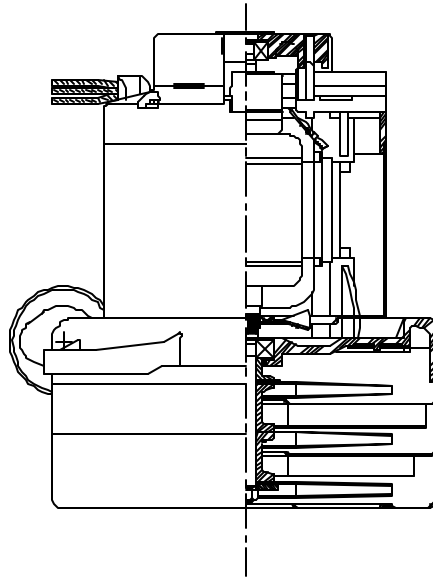

SPECIAL FEATURES

- Suitable for 240 volt AC operation 50/60 Hz
- UL recognized, category PRGY2 (E47185)
- Provision for grounding
- 10 mm shaft and bearing system
- The Lamb Electric vacuum motor line offers a wide range of performance levels to meet design needs

*** Model 117743-13 has epoxy painted fan case and patented air seal bearing construction, U.S. Patent #4,088,424**

TYPICAL MOTOR PERFORMANCE.*

(At 240 volts, 60Hz, test data is corrected to standard conditions of 29.92 Hg, 68° F.)

ASTM DATA

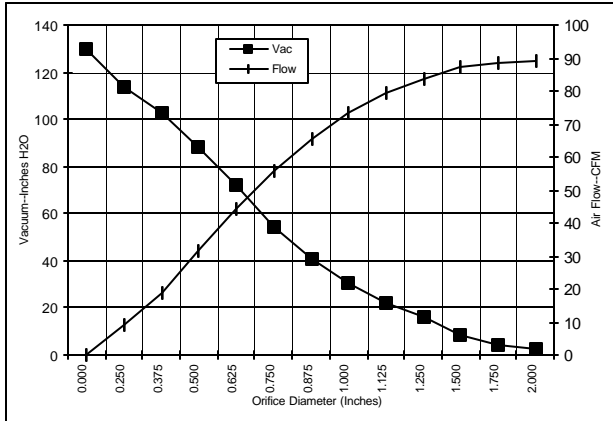

Orifice (Inches)	Amps	Watts (In)	RPM	Vac (In.H ₂ O)	Flow (CFM)	Air Watts
2.000	5.5	1262	17800	2.2	89.2	20
1.750	5.5	1261	17800	4.3	88.2	43
1.500	5.5	1262	17800	8.4	87.4	87
1.250	5.5	1266	17800	16.1	83.8	159
1.125	5.5	1265	17820	22.1	79.5	207
1.000	5.5	1260	17870	30.2	73.4	260
0.875	5.4	1255	17920	40.9	65.4	315
0.750	5.4	1247	18000	54.5	55.5	356
0.625	5.2	1211	18130	71.8	44.2	373
0.500	4.9	1136	18810	88.3	31.4	326
0.375	4.5	1043	19710	102.5	19.0	229
0.250	4.0	942	20810	113.9	8.8	119
0.000	3.5	837	22020	129.5	0.0	0

METRIC DATA

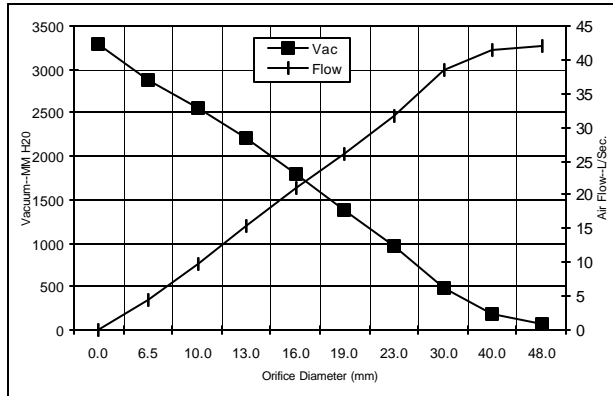

Orifice (mm)	Amps	Watts (In)	RPM	Vac (mm H ₂ O)	Flow (L/Sec)	Air Watts
48.0	5.5	1262	17800	79	41.9	30
40.0	5.5	1262	17800	182	41.4	74
30.0	5.5	1265	17811	493	38.4	185
23.0	5.4	1256	17908	971	31.8	301
19.0	5.4	1246	18003	1393	26.1	356
16.0	5.2	1212	18125	1806	21.1	372
13.0	4.9	1144	18742	2201	15.4	331
10.0	4.6	1057	19575	2549	9.8	244
6.5	4.0	947	20755	2879	4.4	125
0.0	3.5	837	22020	3289	0.0	0

Note: Metric performance data is calculated from the ASTM data above.

* Data represents performance of a typical motor sampled from a large production quantity. Individual motor data may vary due to normal manufacturing variat

Test Specs:	240 volts	Minimum Sealed Vacuum:	125.0"	ORIFICE:	7/8"	Minimum Vacuum:	42.0"	Maximum Watts:	1460
-------------	-----------	------------------------	--------	----------	------	-----------------	-------	----------------	------

DIMENSIONS

NOTES:

1. LEADS: 16GA. STRANDED, ONE BLACK AND ONE WHITE. GROUND LEAD. 18GA. STRANDED; COLOR GREEN WITH YELLOW STRIPE.

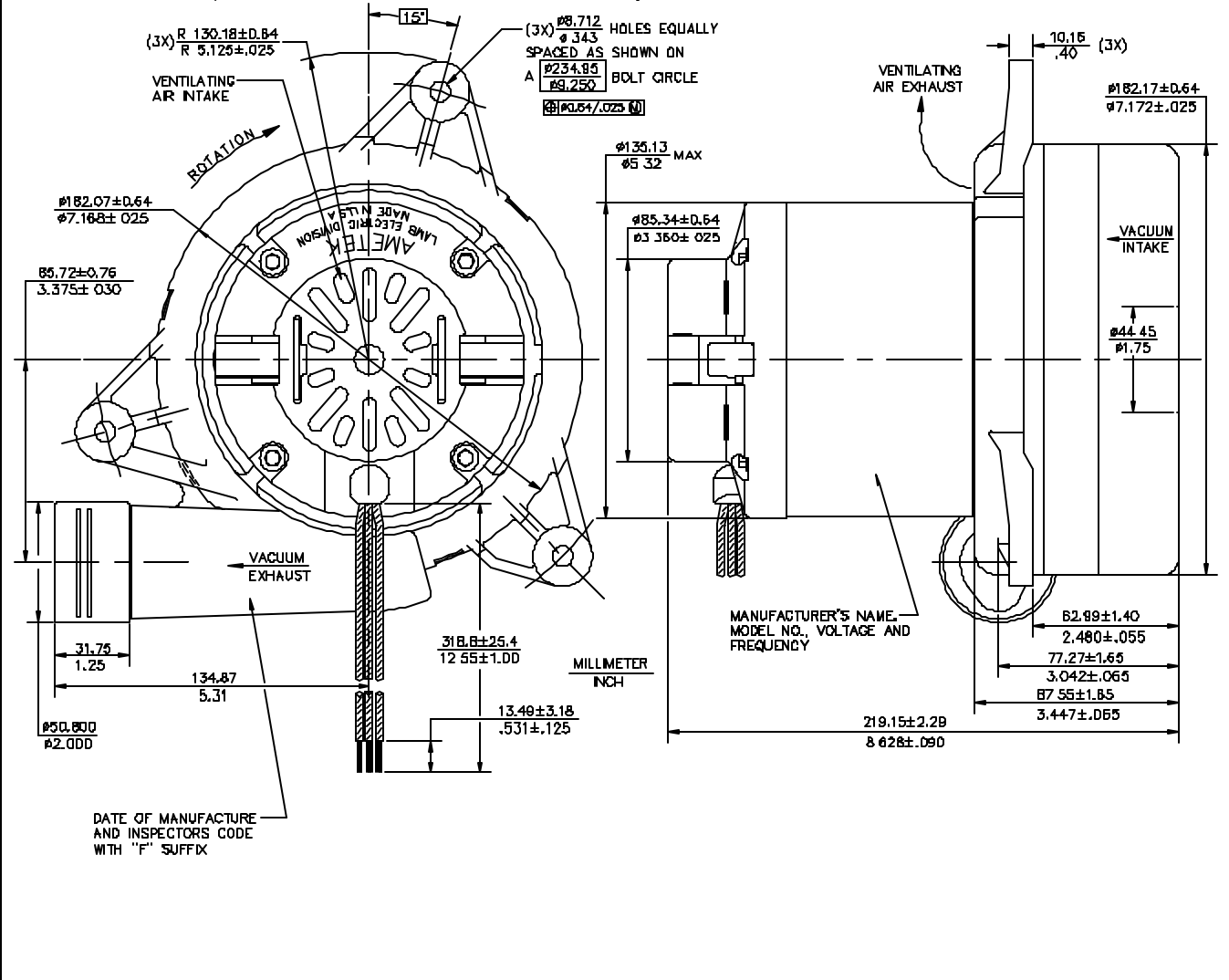

IMPORTANT NOTE: Pictorial and dimensional data are subject to change without notice. Contact factory for current revision levels.

WARNING - When using AMETEK Lamb Electric bypass motors in machines that come in contact with foam, liquid (including water), or other foreign substances, the machine must be designed and constructed to prevent those substances from reaching the fan system, motor housing, and electrical components. Lamb Electric vacuum motors other than hazardous duty models should not be applied in machines that come in contact with dry chemicals or other volatile materials. Failure to observe these precautions could cause flashing (depending on volatility) or electrical shock which could result in property damage and severe bodily injury, including death in extreme cases. All applications incorporating Lamb Electric motors should be submitted to appropriate organizations or agencies for testing specifically related to the safety of your equipment.

AMETEK/Lamb Electric Division
 627 Lake Street
 Kent, Ohio 44240
 U.S.A.
 Tel: (330) 673-3451
 Fax: (330) 673-8994

Ametek GmbH
 Weillindorfer Str. 47
 D-70825 Korntal-Munchingen
 Germany
 Phone: + 49-711-838-7876
 Fax: + 49-711-838-7862

AMETEK/Singapore Private Limited
 10 Ang Mo Kio Street 65
 # 05-12 Techpoint
 Singapore 2056
 Tel: + 65-484-2388
 Fax: + 65-481-6588