

## LAMB ELECTRIC

**Model: 116354-00**  
**116354-13\***

### DESCRIPTION

- Two stage
- 240 volts
- 5.7"/145 mm diameter
- Double ball bearings
- Single speed
- Peripheral bypass discharge
- Thermoset fan end bracket
- Aluminum commutator bracket

### DESIGN APPLICATION

- Equipment operating in environments requiring separation of working air from motor ventilating air
- Designed to handle clean, dry, filtered air only

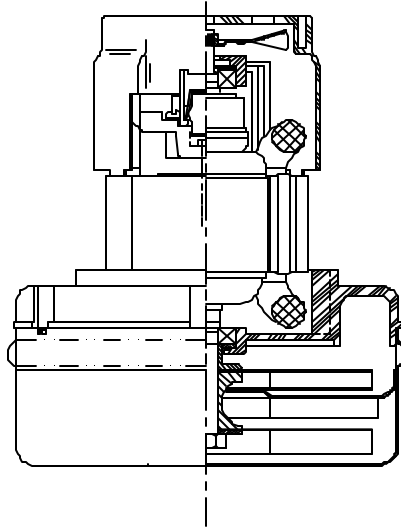

### SPECIAL FEATURES

- Suitable for 240 volt AC operation, 50/60 Hz
- UL recognized, category PRGY2 (E47185)
- Provision for grounding
- Skeleton-frame design
- The Lamb Electric vacuum motor line offers a wide range of performance levels to meet design needs

\* Model 116354-13 has epoxy painted fan case and patented Air Seal Bearing Protection. U.S. Patent #4,088,424

### TYPICAL MOTOR PERFORMANCE.\*

(At 240 volts, 60Hz, test data is corrected to standard conditions of 29.92 Hg, 68° F.)

ASTM DATA

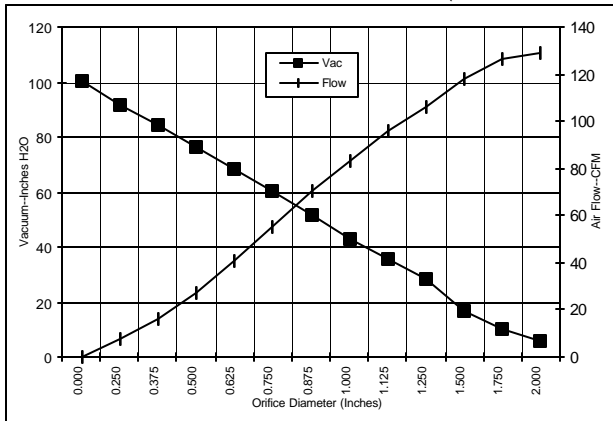

Orifice (Inches)	Amps	Watts (In)	RPM	Vac (In.H <sub>2</sub> O)	Flow (CFM)	Air Watts
2.000	6.4	1435	18454	6.1	128.7	93
1.750	6.5	1448	18388	10.2	126.1	151
1.500	6.5	1456	18343	16.9	117.9	234
1.250	6.5	1454	18343	28.1	105.7	349
1.125	6.4	1437	18496	35.4	95.8	398
1.000	6.2	1399	18836	43.1	83.4	423
0.875	6.0	1354	19239	52.0	70.1	428
0.750	5.7	1287	19835	60.2	55.3	391
0.625	5.3	1193	20583	68.2	40.7	326
0.500	4.9	1108	21572	76.3	27.5	246
0.375	4.5	1029	22547	84.7	16.4	163
0.250	4.2	960	23530	91.8	7.9	85
0.000	4.0	910	24515	100.4	0.0	0

METRIC DATA

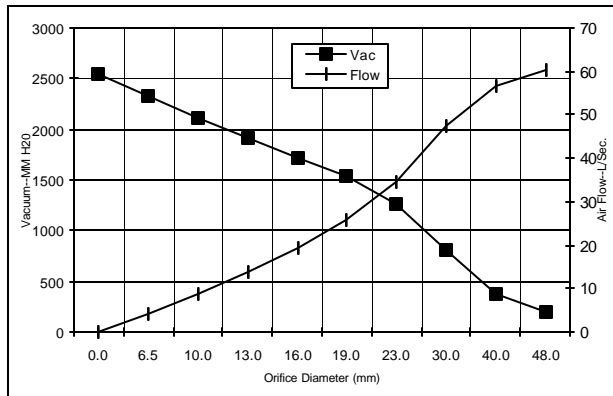

Orifice (mm)	Amps	Watts (In)	RPM	Vac (mm H <sub>2</sub> O)	Flow (L/Sec)	Air Watts
48.0	6.5	1441	18425	201	60.2	119
40.0	6.5	1454	18357	378	56.8	209
30.0	6.5	1445	18427	816	47.3	376
23.0	6.1	1365	19138	1264	34.7	427
19.0	5.7	1285	19850	1533	26.0	390
16.0	5.3	1197	20553	1724	19.5	329
13.0	4.9	1117	21473	1917	13.6	254
10.0	4.6	1041	22401	2119	8.5	175
6.5	4.2	963	23481	2323	3.9	89
0.0	4.0	910	24515	2550	0.0	0

Note: Metric performance data is calculated from the ASTM data above.

\* Data represents performance of a typical motor sampled from a large production quantity. Individual motor data may vary due to normal manufacturing variat

Test Specs:	240 volts	Minimum Sealed Vacuum:	90.0"	ORIFICE:	13 mm	Minimum Vacuum:	65.0"	Maximum Watts:	1200
-------------	-----------	------------------------	-------	----------	-------	-----------------	-------	----------------	------

**DIMENSIONS**

**NOTES:**

1. LEADS 18GA STRANDED, LEADS CAN BE ANY COLOR EXCEPT GREEN OR GREEN WITH YELLOW STRIPE
2. GROUNDING OR EARTHING PROVISIONS USE HOLES AS INDICATED FOR GROUNDING OR EARTHING. REFER TO APPROPRIATE LISTING OR REGULATORY AGENCY FOR PROPER METHOD OF GROUNDING OR EARTHING.
3. RECOMMENDED SCREW SIZE 10-18 TYPE BT OR TYPE 25 THREAD CUTTING SCREW MAXIMUM PENETRATION 17.40/885.

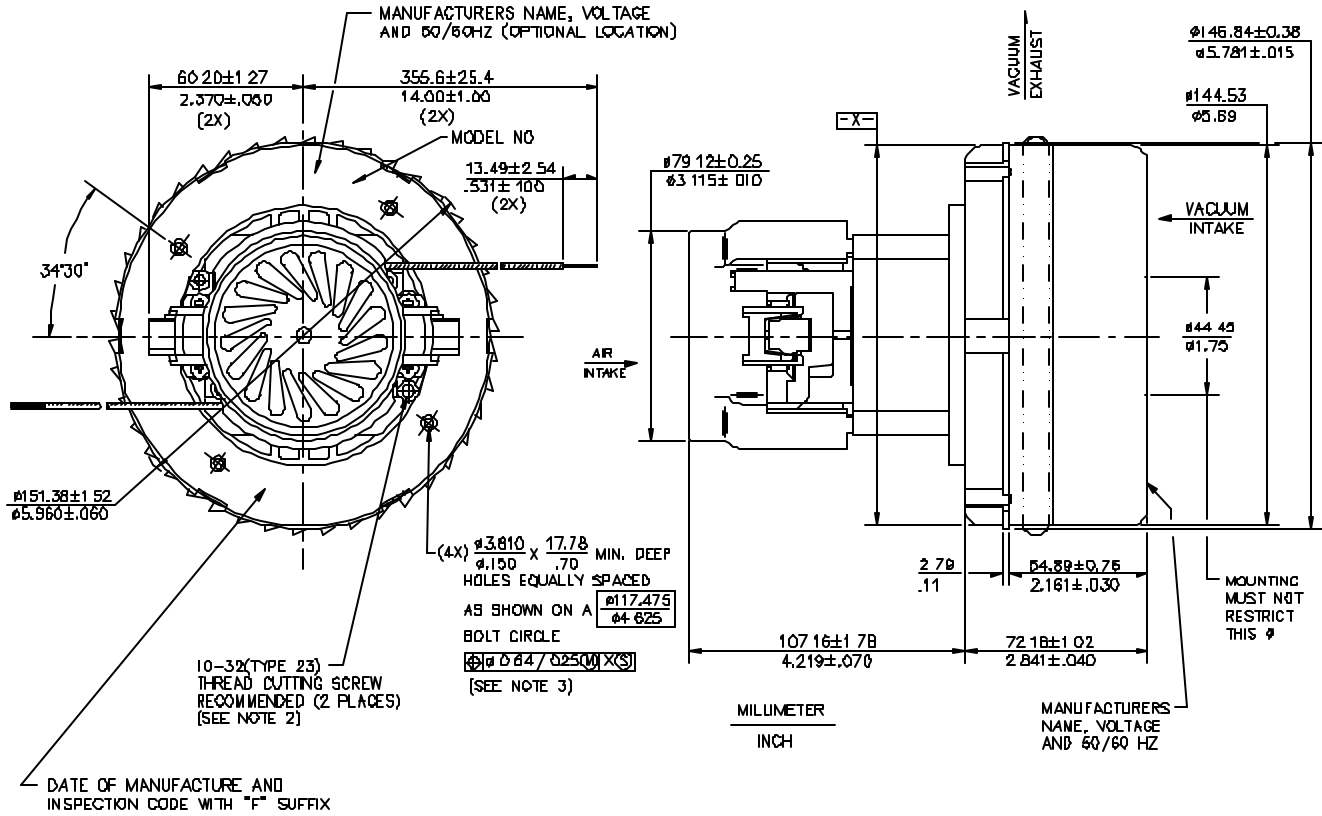

**IMPORTANT NOTE:** Pictorial and dimensional data are subject to change without notice. Contact factory for current revision levels.

**WARNING -** When using AMETEK Lamb Electric bypass motors in machines that come in contact with foam, liquid (including water), or other foreign substances, the machine must be designed and constructed to prevent those substances from reaching the fan system, motor housing, and electrical components. Lamb Electric vacuum motors other than hazardous duty models should not be applied in machines that come in contact with dry chemicals or other volatile materials. Failure to observe these precautions could cause flashing (depending on volatility) or electrical shock which could result in property damage and severe bodily injury, including death in extreme cases. All applications incorporating Lamb Electric motors should be submitted to appropriate organizations or agencies for testing specifically related to the safety of your equipment.

**AMETEK/Lamb Electric Division**  
627 Lake Street  
Kent, Ohio 44240  
U.S.A.  
Tel: (330) 673-3451  
Fax: (330) 673-8994

**Ametek GmbH**  
Weilimdorfer Str. 47  
D-70825 Korntal-Munchingen  
Germany  
Phone: + 49-711-838-7876  
Fax: + 49-711-838-7862

**AMETEK/Singapore Private Limited**  
10 Ang Mo Kio Street 65  
# 05-12 Techpoint  
Singapore 2056  
Tel: + 65-484-2388  
Fax: + 65-481-6588