

LAMB ELECTRIC

Model: 116025-13

DESCRIPTION

- Two stage
- 120 volts
- 5.7"/145 mm diameter
- Double ball bearings
- Single speed
- ACUSTEK® low-noise peripheral bypass discharge
- Thermoset fan end bracket
- Thermoset commutator bracket
- Double insulation

DESIGN APPLICATION

- Equipment operating in environments requiring separation of working air from motor ventilating air
- Designed to handle clean, dry, filtered air only

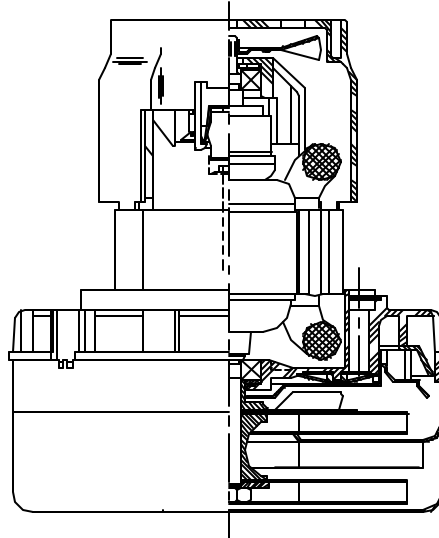

SPECIAL FEATURES

- Suitable for 120 volt AC operation, 50/60 Hz
- UL recognized, category PRGY2 (E47185)
- CSA certified, class 1611 01 (LR31393)
- Skeleton-frame design
- Epoxy painted fan case
- Patented air seal bearing construction. U.S. Patent #4,088,424
- ACUSTEK® low-noise design, U.S. Patent #1,417,2000
- The Lamb Electric vacuum motor line offers a wide range of performance levels to meet design needs

TYPICAL MOTOR PERFORMANCE.*

(At 120 volts, 60Hz, test data is corrected to standard conditions of 29.92 Hg, 68° F.)

ASTM DATA

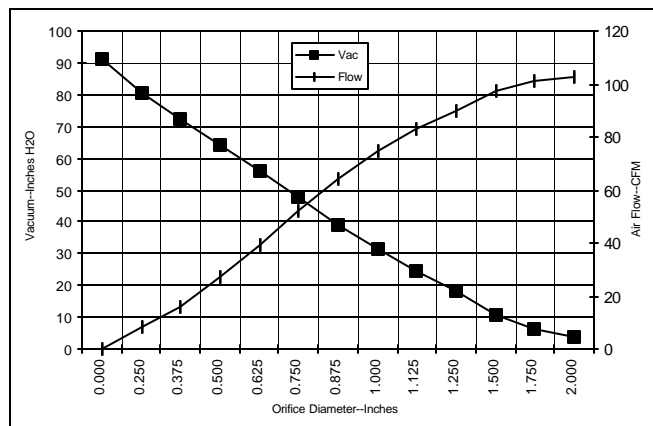

Orifice (Inches)	Amps	Watts (In)	RPM	Vac (In.H ₂ O)	Flow (CFM)	Air Watts
2.000	8.9	1024	18563	3.7	103.0	44
1.750	9.0	1030	18498	6.1	101.0	73
1.500	9.1	1038	18375	10.4	97.0	118
1.250	9.1	1048	18286	18.4	90.0	193
1.125	9.2	1049	18244	24.3	83.0	238
1.000	9.1	1039	18319	31.3	75.0	274
0.875	8.9	1019	18508	39.0	64.0	293
0.750	8.5	980	18935	47.5	52.0	289
0.625	8.0	924	19583	55.8	39.0	256
0.500	7.4	858	20454	64.2	27.0	201
0.375	6.7	784	21474	72.5	16.0	136
0.250	6.1	717	22530	80.7	8.0	71
0.000	5.6	665	23436	91.5	0.0	0

METRIC DATA

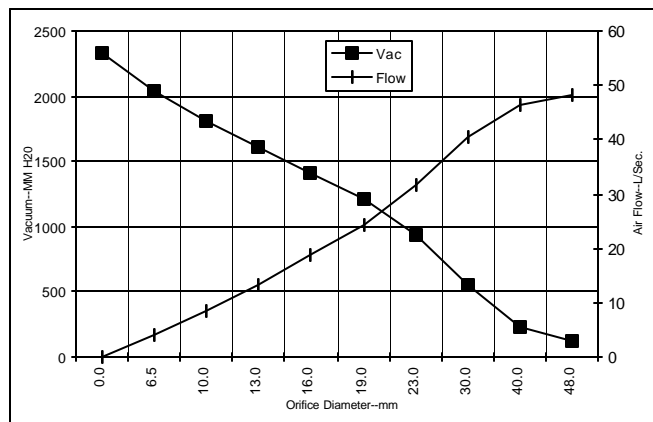

Orifice (mm)	Amps	Watts (In)	RPM	Vac (mm H ₂ O)	Flow (L/Sec)	Air Watts
48.0	8.9	1027	18534	121	48.2	57
40.0	9.1	1036	18412	231	46.4	105
30.0	9.2	1049	18263	550	40.7	218
23.0	9.0	1024	18461	942	31.5	288
19.0	8.5	979	18948	1211	24.4	288
16.0	8.0	926	19557	1409	18.7	257
13.0	7.5	865	20367	1609	13.3	207
10.0	6.8	795	21321	1810	8.3	146
6.5	6.1	720	22477	2039	4.0	74
0.0	5.6	665	23436	2324	0.0	0

Note: Metric performance data is calculated from the ASTM data above.

* Data represents performance of a typical motor sampled from a large production quantity. Individual motor data may vary due to normal manufacturing variati

Test Specs:	120 volts	Minimum Sealed Vacuum:	86.0"	ORIFICE:	7/8 "	Minimum Vacuum:	36.0"	Maximum Watts:	1150
-------------	-----------	------------------------	-------	----------	-------	-----------------	-------	----------------	------

DIMENSIONS

NOTES

- LEADS: 18GA STRANDED, LEADS CAN BE ANY COLOR EXCEPT GREEN OR GREEN WITH YELLOW STRIPE
- RECOMMENDED SCREW SIZE 10-16 TYPE BT OR Z3 THREAD CUTTING SCREW MAXIMUM PENETRATION 17.40/685.

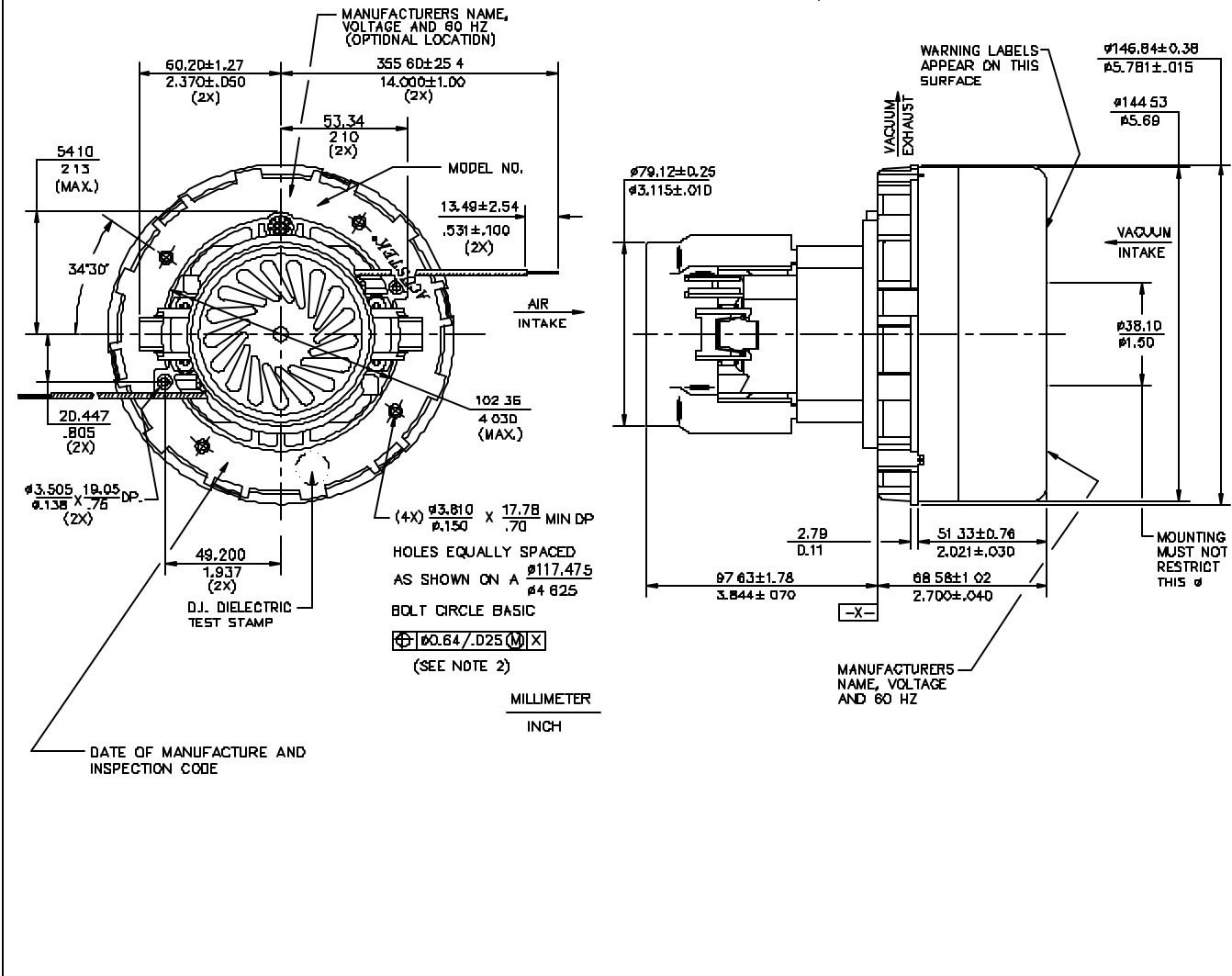

IMPORTANT NOTE: Pictorial and dimensional data are subject to change without notice. Contact factory for current revision levels.

WARNING - When using AMETEK Lamb Electric bypass motors in machines that come in contact with foam, liquid (including water), or other foreign substances, the machine must be designed and constructed to prevent those substances from reaching the fan system, motor housing, and electrical components. Lamb Electric vacuum motors other than hazardous duty models should not be applied in machines that come in contact with dry chemicals or other volatile materials. Failure to observe these precautions could cause flashing (depending on volatility) or electrical shock which could result in property damage and severe bodily injury, including death in extreme cases. All applications incorporating Lamb Electric motors should be submitted to appropriate organizations or agencies for testing specifically related to the safety of your equipment.

AMETEK/Lamb Electric Division
 627 Lake Street
 Kent, Ohio 44240
 U.S.A.
 Tel: (330) 673-3451
 Fax: (330) 673-8994

Ametek GmbH
 Weillimdorfer Str. 47
 D-70825 Korntal-Munchingen
 Germany
 Phone: + 49-711-838-7876
 Fax: + 49-711-838-7862

AMETEK/Singapore Private Limited
 10 Ang Mo Kio Street 65
 # 05-12 Techpoint
 Singapore 2056
 Tel: + 65-484-2388
 Fax: + 65-481-6588